

教育部國教署沉浸式英語教學特色學校試辦計畫

臺北市萬芳國小實施教師共備課程研發及與教學實驗工作坊簽到表

一、工作坊時間：108 年 6 月 3 日(星期一)16:00-18:00

二、工作坊地點：校長室

出席人員	請簽名
高麗鳳校長	高麗鳳
陳韻如主任	陳韻如
林念慈老師	林念慈
李嘉澍老師	李嘉澍
羅丰燕老師	羅丰燕
專家 吳麗君教授	
專家 陳錦芬教授	
專家 謝宜君教授	

教育部國教署沉浸式英語教學特色學校試辦計畫  
臺北市萬芳國小 107 學年-2 度實施教師共備課程  
研發及與教學實驗工作坊會議 教案分享 10

講座照片



講座名字：李嘉澍老師

講座演講的日期/時間：

1080603 / 16:00-18:00PM

演講地點：校長室

講座名字：李嘉澍老師

講座演講的日期/時間：

1080603 / 16:00-18:00PM

演講地點：校長室

## 教育部國教署沉浸式英語教學特色學校試辦計畫

### 臺北市萬芳國小實施教師共備課程研發及與教學實驗工作坊會議紀錄

一、開會時間：108年6月3日(星期一)16:00-18:00

二、開會地點：校長室

三、主持人：高校長麗鳳

記錄：李嘉澍

四、出席人員：如簽到表

五、會議內容

#### (一)主持人報告

5月20日本專案計畫指派台師大英語學系陳純音教授及國北教大音樂學系楊淑媚教授，教授們提供許多具體意見，請李老師及羅老師根據專家的意見來修正教學設計內容。

#### (二)教師共備課程設計-報告人：李嘉澍

本次報告第二學期第三單元第1-6節教學活動設計內容，已根據專家教授的指導意見再次研修，修正後內容如下。

領域/科目	藝術領域/音樂科		設計者	李嘉澍、羅丰燕、高麗鳳
實施年級	三年級	總節數	8節(240分鐘)	
單元名稱	三、動物嘉年華			
設計依據				
學習重點	學習表現	音 1-II-1 能透過聽唱、聽奏及讀譜，建立與展現歌唱及演奏的基本技巧，以表達情感。 音 1-II-2 能依據引導，感知與探索音樂元素，嘗試簡易的即興，表達自我的感受。 音 2-II-1 能使用音樂語彙、肢體等多元方式，回應聆聽的感受。 音 2-II-2 能認識與描述樂曲創作背景，體會音樂與生活的關聯。 音 3-II-1 能參與音樂活動，並展現聆賞禮儀。		核心素養
	學習內容	音 E-II-1 多元形式歌曲，如：獨唱、齊唱等。基礎歌唱技巧，如：聲音探索、姿勢等。 音 E-II-2 簡易節奏樂器、曲調樂器的基礎演奏技巧。 音 E-II-3 讀譜方式，如：五線譜、唱名法、拍號等。		
		藝-E-A1 參與藝術活動，探索生活美感。 藝-E-B1 理解藝術符號，以表達情意觀點。 藝-E-B3 感知藝術與生活的關聯，以豐富美感經驗。 藝-E-C1 識別藝術活動中的社會議題。 藝-E-C2 透過藝術實踐，學習理解他人感受與團隊合作的能		



	音 E-II-4 音樂元素，如：節奏、力度、速度等。 音 E-II-5 簡易即興，如：肢體即興、節奏即興、曲調即興等。 音 A-II-1 器樂曲與聲樂曲，如：獨奏曲、臺灣歌謠、藝術歌曲，以及樂曲之創作背景。 音 A-II-2 相關音樂語彙 音 A-II-3 肢體動作、語文表述、繪畫及戲劇等回應方式。 音 P-II-1 音樂活動、音樂會禮儀	力。 藝-E-C3 體驗在地及全球藝術與文化的多元性。
--	---	-----------------------------------

### 設計理念

帶領學生運用身體來製造各種音效或動作。以歡樂頌為主要旋律，加入直笛及身體打擊樂器來做合奏。藉由欣賞動物狂歡節歌曲認識弦樂器家族並感受音樂的不同。認識並學習運用音樂數位介面創作音樂。

議題融入	學習主題	國際教育-國際素養、資訊科技-資訊科技與合作共創
	實質內涵	國 E5 體認國際文化的多樣性。 國 E6 具備學習不同文化的意願與能力。 資 E4 認識常見的資訊科技共創工具的使用方法。 資 E5 使用資訊科技與他人合作產出想法與作品。
與其他領域/科目的連結		社會領域、科技領域
教材來源		自編
教學設備/資源		電腦、單槍投影機、電子白板

### 學習目標

- 1.帶領學生運用身體來製造各種音效或動作。
- 2.以歡樂頌為主要旋律，加入直笛及身體打擊樂器來做合奏。
- 3.藉由欣賞動物狂歡節歌曲認識弦樂器家族並感受音樂的不同。
- 4.認識並學習運用音樂數位介面創作音樂。

### 教學活動設計

教學活動內容及實施方式	英語相關知識
===== 第一節開始 Lesson one beginning ===== 壹、引起動機 (Warm up and review) 一、課堂打招呼 (Greeting ready) T: Good morning / afternoon	5mins

<p>S: Good morning / afternoon  T: Are you ready for this lesson?  S: Yes, ready.  T: Pay attention to me. Today, we will learn something new.</p> <p>二、簡介本節課主要學習 (Introduce students what they will learn)  T: Today we are going to show you how to make lots of playing parts together.</p> <p>三、問題提問 (Ask some questions)  T: How do you feel about that?  T: Sounds good?  S: "Yes".  T: Very Good. Let's play some new movements.</p> <p>貳、發展活動 (Presentation &amp; practice)</p> <p>一、Warm Up</p> <ul style="list-style-type: none"> <li>● Can you turn your face from left side to right side while you conducting? Show me you can do that.</li> <li>● Can you give a sign to ask players to change their dynamics?</li> </ul> <p>二、Movement</p> <ul style="list-style-type: none"> <li>● Turn your face from left side to right side while you conducting.</li> <li>● Give sign to any specific part.</li> <li>● Change the dynamics while the players playing the music.</li> </ul> <p>參、綜合活動 (Wrap-up)</p> <p>一、Review new words.  Use the flashcard (PowerPoint file) to review the new words.</p> <p>二、Review sentence patterns.</p> <p>三、Collaborate  Divide students into 3 groups: "group one", "group two" and "group three".  They can choose their "weapon" to play the music: recorder, tambourine or vocal.</p> <p>===== 第一節結束 Lesson one ending =====</p>	25mins	
<p>===== 第二節開始 Lesson two beginning =====</p> <p>壹、引起動機 (Warm up and review)</p> <p>一、課堂打招呼 (Greeting ready)</p> <p>T: Good morning / afternoon  S: Good morning / afternoon</p>	5mins	

<p>T: Are you ready for this lesson? S: Yes, ready. (Learning materials check procedure.) T: Do you know any animal(in zoo)? S: (etc.)</p> <p>二、簡介本節課主要學習 (Introduce students what they will learn from this lesson) T: Today we are going to learn the "Le Carnaval des Animaux" (The Carnival of the Animals).</p> <p>三、問題提問 (Ask some questions) T: Did you ever hear any music about the animal before? Please raise your hand if you have heard any music about the animal. Good job.</p> <p>貳、發展活動 (Presentation &amp; practice)</p> <p>一、 Play the video. <a href="https://www.youtube.com/watch?v=8y-KBIDFZOo">https://www.youtube.com/watch?v=8y-KBIDFZOo</a> (music only) Okay, it is music about the animal. What kind of animal is? (Show answer in the next slide) Which musical instrument plays the part? Strings. (Lion)</p> <p>二、 Play the video. Let's listen to the music and guess again. <a href="https://www.youtube.com/watch?v=cXEy_UfSgCU">https://www.youtube.com/watch?v=cXEy_UfSgCU</a> (music only) It is music about the animal, too. What kind of animal is? (Show answer in the next slide) Which musical instrument plays the part? Cello. (Swan) Answer : <a href="https://www.youtube.com/watch?v=3qrKjywjo7Q">https://www.youtube.com/watch?v=3qrKjywjo7Q</a></p> <p>三、 Play the video Let's listen to the music and guess again. <a href="https://www.youtube.com/watch?v=fInVDoCnsNk">https://www.youtube.com/watch?v=fInVDoCnsNk</a> (music only) It is also music about the animal. What kind of animal is? (Show answer in the next slide) Which musical instrument plays the part? Double Bass. (Elephant) Answer : <a href="https://www.youtube.com/watch?v=h5UNpU8HHtU">https://www.youtube.com/watch?v=h5UNpU8HHtU</a></p> <p>四、 About "The Carnival of the Animals"</p>	25mins	carnival
---	--------	----------

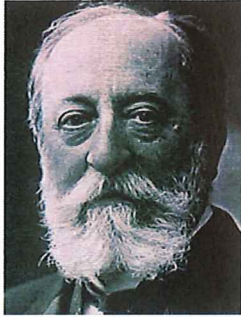

The Carnival of the Animals (Le Carnaval des Animaux) is a humorous musical suite of fourteen movements by the French Romantic composer Camille Saint-Saëns. The work was written for private performance by an ad hoc ensemble of two pianos and other instruments and lasts around 25 minutes.

**參、綜合活動 (Wrap-up)**

一、 Review new words by games.

Use the flashcard (PowerPoint file) to review the new words. Listen and then make a comparison between different music.

二、 Review sentence patterns.

三、 Can you create a rhythm pattern?

===== 第二節結束 Lesson two ending =====

10mins

Saint-Saëns

===== 第三節開始 Lesson three beginning =====

**壹、引起動機 (Warm up and review)**

一、 課堂打招呼 (Greeting ready)

T: Good morning / afternoon

S: Good morning / afternoon

T: Are you ready for this lesson?

S: Yes, ready.

T: Pay attention to me. Let's make an acapella team.

二、 簡介本節課主要學習 (Introduce students what they will learn)

T: Today we are going to combine the vocal and body percussion together.

三、 問題提問 (Ask some questions)

T: Without the conductor, can we play great or just fine?

S: "No", "Yes"?

T: Okay, let's do it today.

5mins

25mins

**貳、發展活動 (Presentation & practice)**

Teacher shows how to use footsteps for the stubborn part, and singing with the clap



hands or something else.



Tips:

- Keep footsteps steadily in 4 beats.
- Keep vocal singing steadily in 4 beats.
- Make some changes in clap hands.

**參、綜合活動 (Wrap-up)**

一、 Review new words.

Use the flashcard (PowerPoint file) to review the new words.

二、 Review sentence patterns.

三、 Divide students into groups. Let them have their own performance in different ways.

===== 第三節開始 Lesson three ending =====

10mins

===== 第四節開始 Lesson four beginning =====

**壹、引起動機 (Warm up and review)**

一、 課堂打招呼 (Greeting ready)

T: Good morning / afternoon

S: Good morning / afternoon

T: Are you ready for this lesson?

S: Yes, ready.

T: Pay attention to me. Today, we will learn something new.

二、 簡介本節課主要學習 (Introduce students what they will learn)

T: From now on, we are going to prepare our performance which will be held in the last class we meet.

三、 問題提問 (Ask some questions)

T: Which part do you like to play? The vocal part, tambourine part or body percussion?

5mins

**貳、發展活動 (Presentation & practice)**

Ask students to write down their scores, and then play their scores on their own.

15mins

**參、綜合活動 (Wrap-up)**

一、 Review new words.

Use flashcard (PowerPoint file) to review the new words.

20mins



<p>二、 Review sentence patterns.</p> <p>三、 "Welcome to Our Acapella Squad."</p> <p>==== 第四節結束 Lesson four ending =====</p>		
<p>==== 第五節開始 Lesson five beginning =====</p> <p>壹、引起動機 (Warm up and review)</p> <p>一、 課堂打招呼 (Greeting ready)</p> <p>T: Good morning / afternoon</p> <p>S: Good morning / afternoon</p> <p>T: Are you ready for this lesson?</p> <p>S: Yes, ready.</p> <p>T: Pay attention to me. Today, we will learn something new.</p> <p>二、 簡介本節課主要學習 (Introduce students what they will learn)</p> <p>T: Today, we will let you know what the MIDI is. MIDI is a technology which combines music instruments with computer. The composer can use MIDI system to create their music.</p> <p>三、 問題提問 (Ask some questions)</p> <p>T: What different between natural music instrument and electronic music instrument?</p> <p>T: Do they sound like the same?</p> <p>T: Have you ever play music with electronic music instrument before?</p> <p>貳、發展活動 (Presentation &amp; practice)</p> <p>一、 What is MIDI?</p> <p>音樂數位介面 ( Musical Instrument Digital Interface , 簡稱 MIDI ) 是一個工業標準的電子通訊協定, 為電子樂器等演奏裝置 ( 如合成器 ) 定義各種音符或彈奏碼, 容許電子樂器、電腦、手機或其它的舞台演出配備彼此連接, 調整和同步, 得以即時交換演奏資料。</p> <p>MIDI 不傳送聲音, 只傳送像是音調和音樂強度的資料, 音量, 顫音和相位 [1]等參數的控制訊號, 還有設定節奏的時鐘訊號。在不同的電腦上, 輸出的聲音也因音源器不同而有差異</p> <p>二、 Structure</p> <p>natural music instrument - piano</p>	<p>5mins</p> <p>25mins</p>	

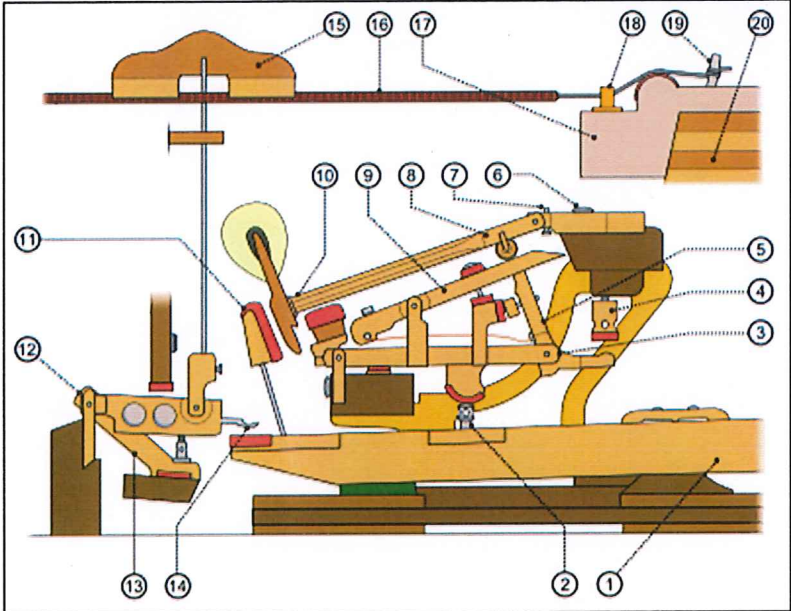

Electronic music instrument - piano

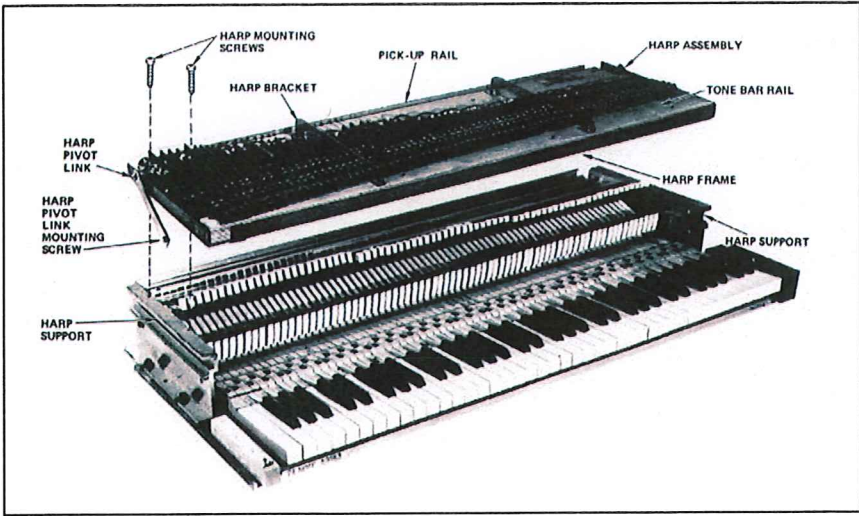



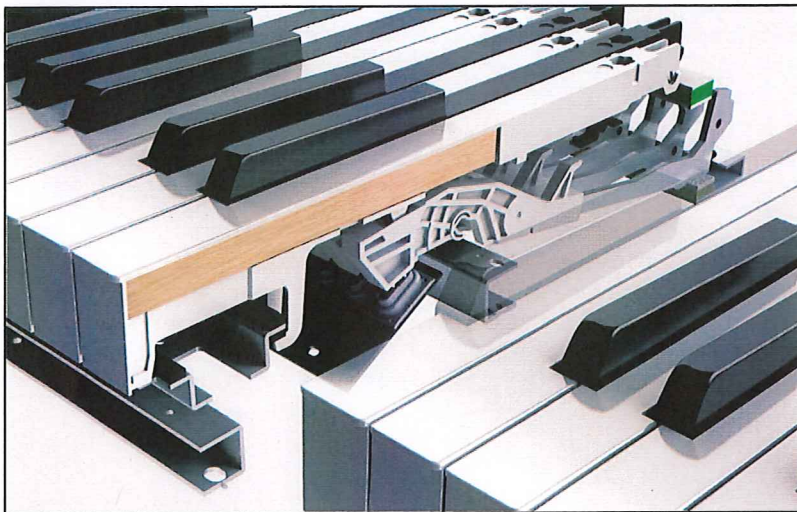

三、Sound

natural piano vs electronic(digital) piano

<https://www.youtube.com/watch?v=pUJDf5-8V44>

natural violin vs electronic violin

<https://www.youtube.com/watch?v=aq8ksT5NA7s&t=22s>

natural drums vs electronic drums

<https://www.youtube.com/watch?v=qJl2uXNxXyA>

T: Which one you prefer? why?

參、綜合活動 (Wrap-up)

一、Review new words.

Use flashcard (PowerPoint file) to review the new words.

二、Review sentence patterns.

三、Do you like natural music instrument or electronic music instrument?

==== 第五節結束 Lesson five ending =====

===== 第六節開始 THE SIX-LESSON BEGINNING =====

5mins



壹、引起動機 (Warm up and review)

一、課堂打招呼 (Greeting ready)

T: Good morning / afternoon

S: Good morning / afternoon

T: Are you ready for this lesson?

S: Yes, ready.

T: Pay attention to me. Today, we will learn something new.

二、簡介本節課主要學習 (Introduce students what they will learn)

T: Today, we will give you a set of MIDI and let you play with it. I wish you can have a good experience in this trip.

三、問題提問 (Ask some questions)

T: Which instrument simulation is your favorite? why?

5mins

貳、發展活動 (Presentation & practice)

一、Preparing

1. Connect MIDI controller(keyboard) with portable device(iPad or Android pad) by lighting OTG or micro USB OTG connector.

30mins



2. Turn on the APP.(iOS: Garageband, Android: Walk Band)

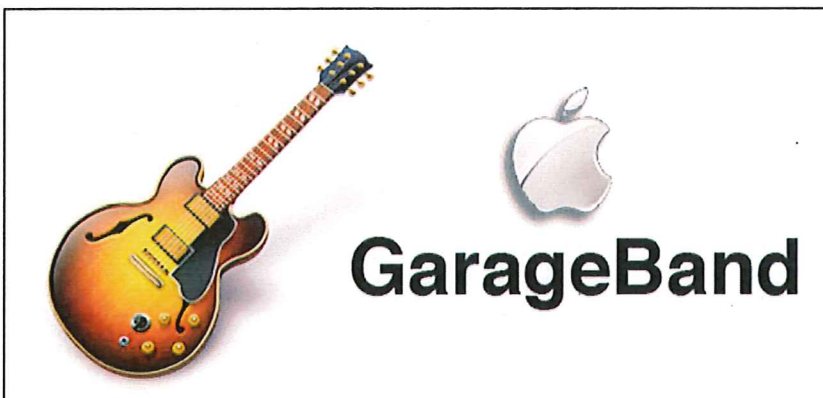



3. Play some notes by preset voice (piano, usually)

二、 How to switch another instrument?

三、 How to change octave?

**參、綜合活動 (Wrap-up)**

一、 Review new words.

Use flashcard (PowerPoint file) to review the new words.

二、 Review sentence patterns.

===== 第六節結束 Lesson six ending =====

===== 第七節開始 THE SEVENTH-LESSON BEGINNING =====

**壹、引起動機 (Warm up and review)**

一、 課堂打招呼 (Greeting ready)

T: Good morning / afternoon

S: Good morning / afternoon

T: Are you ready for this lesson?

S: Yes, ready.

T: Pay attention to me. Today, we have learned about playing part of score "Ode to Joy".

二、 簡介本節課主要學習 (Introduce students what they will learn)

Teacher shows the score of "Ode to Joy". And assign students to play this music.

三、 問題提問 (Ask some questions)

T: What instrument do you like?

**貳、發展活動 (Presentation & practice)**

Ask students play their music.

5mins

5mins

15mins

<p><b>參、綜合活動 (Wrap-up)</b></p> <p>一、 Review new words. Use flashcard (PowerPoint file) to review the new words.</p> <p>二、 Review sentence patterns.</p> <p>三、 "Welcome to Our Orchestra !"</p> <p>===== 第八節結束 THE EIGHTH-LESSON ENDING =====</p>	20mins	
<p>學習評量：奧福音樂節奏表示法、Body Percussion、平板電腦鋼琴 APP(iOS:Garageband / Android:Walk Band)</p>		
<p>參考資料：</p> <p>unit 1:</p> <ol style="list-style-type: none"> <li>1. <a href="https://www.youtube.com/watch?v=QLj_gMBqHX8">https://www.youtube.com/watch?v=QLj_gMBqHX8</a></li> <li>2. <a href="https://www.youtube.com/watch?v=pzlw6fUux4o">https://www.youtube.com/watch?v=pzlw6fUux4o</a></li> <li>3. <a href="https://www.youtube.com/watch?v=ElxtHSp3_w8&amp;t=794s">https://www.youtube.com/watch?v=ElxtHSp3_w8&amp;t=794s</a></li> <li>4. <a href="https://www.youtube.com/watch?v=tRTVoN95miM">https://www.youtube.com/watch?v=tRTVoN95miM</a></li> <li>5. <a href="https://www.youtube.com/watch?v=Q7SI7N22k_A">https://www.youtube.com/watch?v=Q7SI7N22k_A</a></li> <li>6. <a href="https://www.youtube.com/watch?v=LK4pmJQ6zgM">https://www.youtube.com/watch?v=LK4pmJQ6zgM</a></li> <li>7. <a href="https://www.youtube.com/watch?v=8gOqSfJN_gA">https://www.youtube.com/watch?v=8gOqSfJN_gA</a></li> <li>8. <a href="https://www.youtube.com/watch?v=DAV74hzbj7w">https://www.youtube.com/watch?v=DAV74hzbj7w</a></li> <li>9. <a href="https://www.youtube.com/watch?v=9TpvTEb4BaQ">https://www.youtube.com/watch?v=9TpvTEb4BaQ</a></li> <li>10. <a href="https://www.youtube.com/watch?v=GaldGEEsUyME">https://www.youtube.com/watch?v=GaldGEEsUyME</a></li> <li>11. <a href="https://www.youtube.com/watch?v=bL7ZLp0L17E">https://www.youtube.com/watch?v=bL7ZLp0L17E</a></li> <li>12. <a href="https://www.youtube.com/watch?v=tF5kr251BRs#t=16s">https://www.youtube.com/watch?v=tF5kr251BRs#t=16s</a></li> <li>13. <a href="https://www.youtube.com/watch?v=FCi2u265wxQ">https://www.youtube.com/watch?v=FCi2u265wxQ</a></li> <li>14. <a href="https://www.youtube.com/watch?v=PIN2c22xJRY">https://www.youtube.com/watch?v=PIN2c22xJRY</a></li> <li>15. <a href="https://www.youtube.com/watch?v=WdB82xdSWIE#t=1m9s">https://www.youtube.com/watch?v=WdB82xdSWIE#t=1m9s</a></li> <li>16. <a href="https://www.youtube.com/watch?v=RLDF8OeD-hc#t=55s">https://www.youtube.com/watch?v=RLDF8OeD-hc#t=55s</a></li> <li>17. <a href="https://www.youtube.com/watch?v=ASB6hFUat4g#t=41">https://www.youtube.com/watch?v=ASB6hFUat4g#t=41</a></li> </ol> <p>unit 2:</p> <ol style="list-style-type: none"> <li>1. <a href="https://www.youtube.com/watch?v=rOjHhS5MtvA#t=1h6m34s">https://www.youtube.com/watch?v=rOjHhS5MtvA#t=1h6m34s</a></li> <li>2. <a href="https://www.youtube.com/watch?v=I_iBqqQTmhs">https://www.youtube.com/watch?v=I_iBqqQTmhs</a></li> <li>3. <a href="https://www.youtube.com/watch?v=p24u3JzgMnc">https://www.youtube.com/watch?v=p24u3JzgMnc</a></li> <li>4. <a href="https://www.youtube.com/watch?v=BvHtqYC8azs">https://www.youtube.com/watch?v=BvHtqYC8azs</a></li> <li>5. <a href="https://www.youtube.com/watch?v=_KtCPKj2UTI">https://www.youtube.com/watch?v=_KtCPKj2UTI</a></li> <li>6. <a href="https://www.youtube.com/watch?v=sx4kvdqA014">https://www.youtube.com/watch?v=sx4kvdqA014</a></li> </ol>		



7. [https://www.youtube.com/watch?v=\\_mVW8tgGY\\_w](https://www.youtube.com/watch?v=_mVW8tgGY_w)
8. <https://www.youtube.com/watch?v=p24u3JzgMnc>
9. <https://www.youtube.com/watch?v=7ZEzAD1uGlw>
10. <https://www.youtube.com/watch?v=awSdzWRPcJo>
11. <https://www.youtube.com/watch?v=JKG8ZxEOdWE>

unit 3:

1. <https://www.youtube.com/watch?v=8y-KBIDFZOo>
2. [https://www.youtube.com/watch?v=cXEy\\_UfSgCU](https://www.youtube.com/watch?v=cXEy_UfSgCU)
3. <https://www.youtube.com/watch?v=3qrKjywj07Q>
4. <https://www.youtube.com/watch?v=fInVDoCnsNk>
5. <https://www.youtube.com/watch?v=h5UNpU8HHtU>
6. <https://www.youtube.com/watch?v=pUJDf5-8V44>
7. <https://www.youtube.com/watch?v=aq8ksT5NA7s&t=22s>
8. <https://www.youtube.com/watch?v=qJI2uXNxXyA>

附錄：

七、散會：下午 18:00